

3646

Horizontal Shaft Impactor

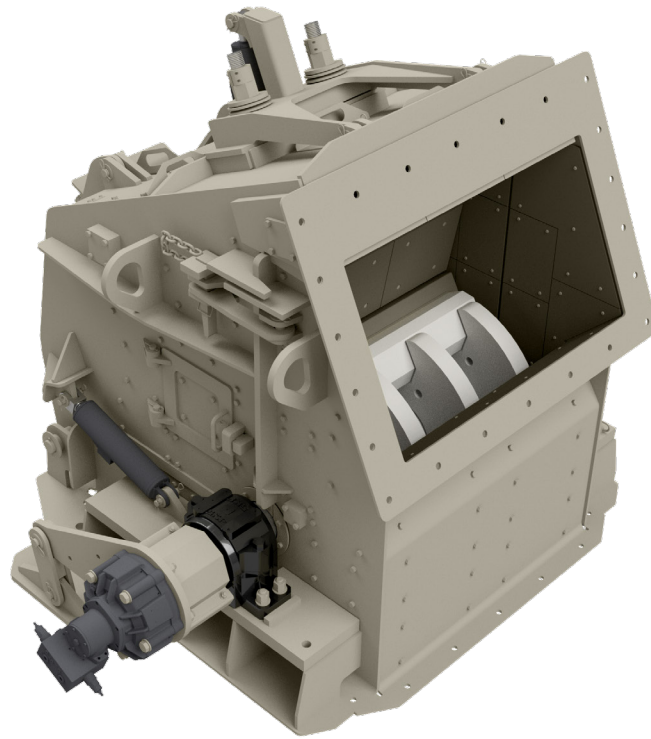

Inlet Opening

- 26" x 46"

Rotor

- Variable speed of 675-900 RPM (92-bar)
- Variable tip speed of 5,500-7,000 fpm max
- Diameter of 36"
- Width of 46"
- Blow bar weight of 450lb each

Power

- Hydraulic motor

Plant Capacity

- Up to 250 TPH (tonnages will vary with conditions)

Physical/Operating Characteristics

Dimension	Standard	Metric
Operating Length	7' 4"	2.2m
Operating Height	6' 5"	1.9m
Operating Width	8' 1"	2.5m
Feed Height	3' 4"	1.02m
Unit Weight	15,145lb	6,870kg

