

5054

Hybrid HSI

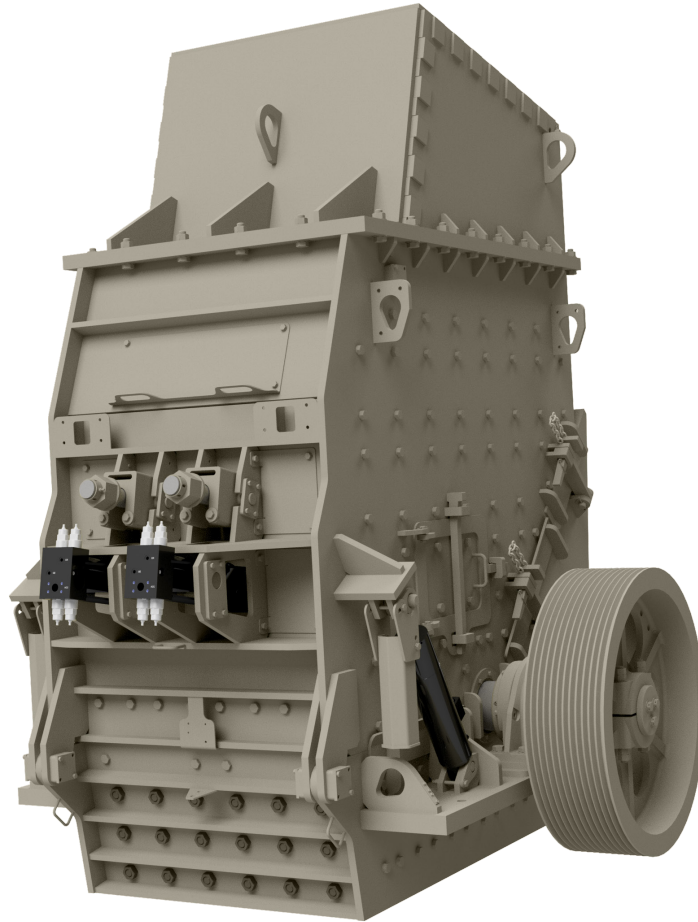

Rotor Assembly

- SAE4150 solid steel shaft
- Grease lubricated spherical roller self-aligning type bearings
- 3-bar MPR segmented rotor design
- 8V rotor sheave

Impact Hammers

- Cast design
- Rigid mounting

Primary Aprons

- Fully-lined with Abrasion-resistant steel
- Hydraulic assist shim adjust
- Hydraulic relief

Crusher Housing

- Fabricated plate
- Rear section opens for easy access
- 1" Abrasion-resistant steel chamber liners
- Fabricated steel plate feed box with impact bars and chain curtain

Options

- Hydraulic anti-bridging feed plate with pump and electric motor (less starter & wiring)
- V-belt drive with motor sheave and v-belts
- V-belt guard
- Discharge chute – for stationary plants
- Liners for discharge chute
- Electric or diesel power unit

Physical and Operating Characteristics

Dimension	Standard	Metric
HSI Feed Opening Width	53"	1,473mm
HSI Feed Opening Height	58"	1,346mm
Approx. Capacity	400-750 TPH	364-682 MTPH
Rotor Width	50"	1,270mm
Rotor Diameter	43"	1,092mm
Blow Bar Weight	1,010lb each	460kg each
Base Weight	34,300lb	15,560kg
Rotor Weight	19,000lb	8,620kg
Feed Hood and Curtain Weight	7,700lb	3,500kg
Total Weight	61,000lb	27,670kg
Recommended Power Diesel	450hp	335 kW
Recommended Power Electric	300hp	224 kW
Rotor RPM Range	450 - 600	

Dimension	Standard	Metric
Rotor Tip Speed Range	5,065 - 6,750 FPM	1,544 - 2,057 MPM
Apron Setting Range	4" - 8"	102 - 203mm
Operating Length	136"	3,452mm
Operating Width	104"	2,652mm
Operating Height	153"	3,891mm
*Operating envelope based on closed crusher		
Service Length	175"	4,441mm
Service Width	104"	2,652mm
Service Height	181"	4,601mm
*Service envelope based on open crusher		

