

RANGER™ SF10

Mobile Incline Screen

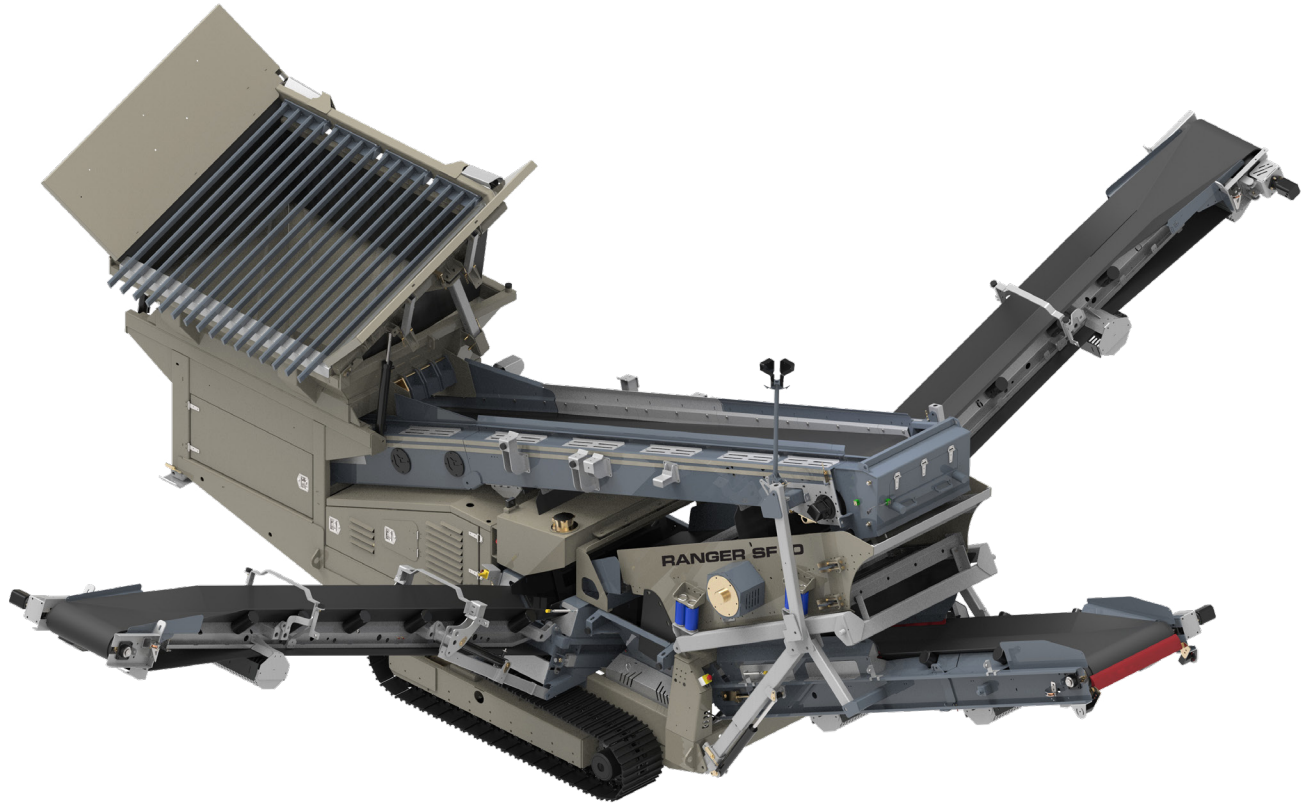

Hopper/Feeder

- 4.25 cubic yard (3.25 cubic meter) capacity
- Hydraulic support legs
- Hydraulic remote tipping grid with foldable wing extensions
- Replaceable borox grid bars at 4" (102mm) spacing

Delivery Conveyor

- 22' x 32" (6,706 x 800mm) conveyor with hydraulic drive

Product Conveyors

- Two 18' x 24" (5,486 x 600mm) conveyors
- Discharge height: 8' 10" (2,438 x 2,700mm)
- Hydraulically folds for transport

Power Unit

- Deutz D2011 L04I (EU Stage IIIA, EPA Tier 3) 49hp (36kw)
- Deutz TCD2.2 L3 (EU Stage V, EPA Tier 4) 74hp (55kw)
- 26 gal (100L) fuel tank
- 100 gal (380L) hydraulic oil reservoir

Fines Conveyor

- 24' x 32" (7,315 x 800mm) conveyor
- Hydraulically folds for transport
- Discharge height: 7' 11" (2,400mm)

Vibrating Screen

- Bolted, 2-deck, 2-bearing screen
- Screen box: 4' x 9' 5" (1,219 x 2,870mm)

Options

- Vibrating grid with mesh frame
- Vibrating grid with grid deck
- Shredder
- Wireless track remote
- Tier III engine configuration (export only)
- Complete wash system
- Screen media

Physical/Operating Characteristics

Dimension	Standard	Metric
Operating Length	32' 9"	10m
Operating Width	36'	11m
Operating Height	11' 6"	3.56m
Travel Length	28' 7"	8.72m
Travel Width	7' 7"	2.33m
Travel Height	8' 5"	2.6m
Unit Weight	25,350lb	11,500kg
Feed Height	11' 6"	3.56m

